

CUTSHEET

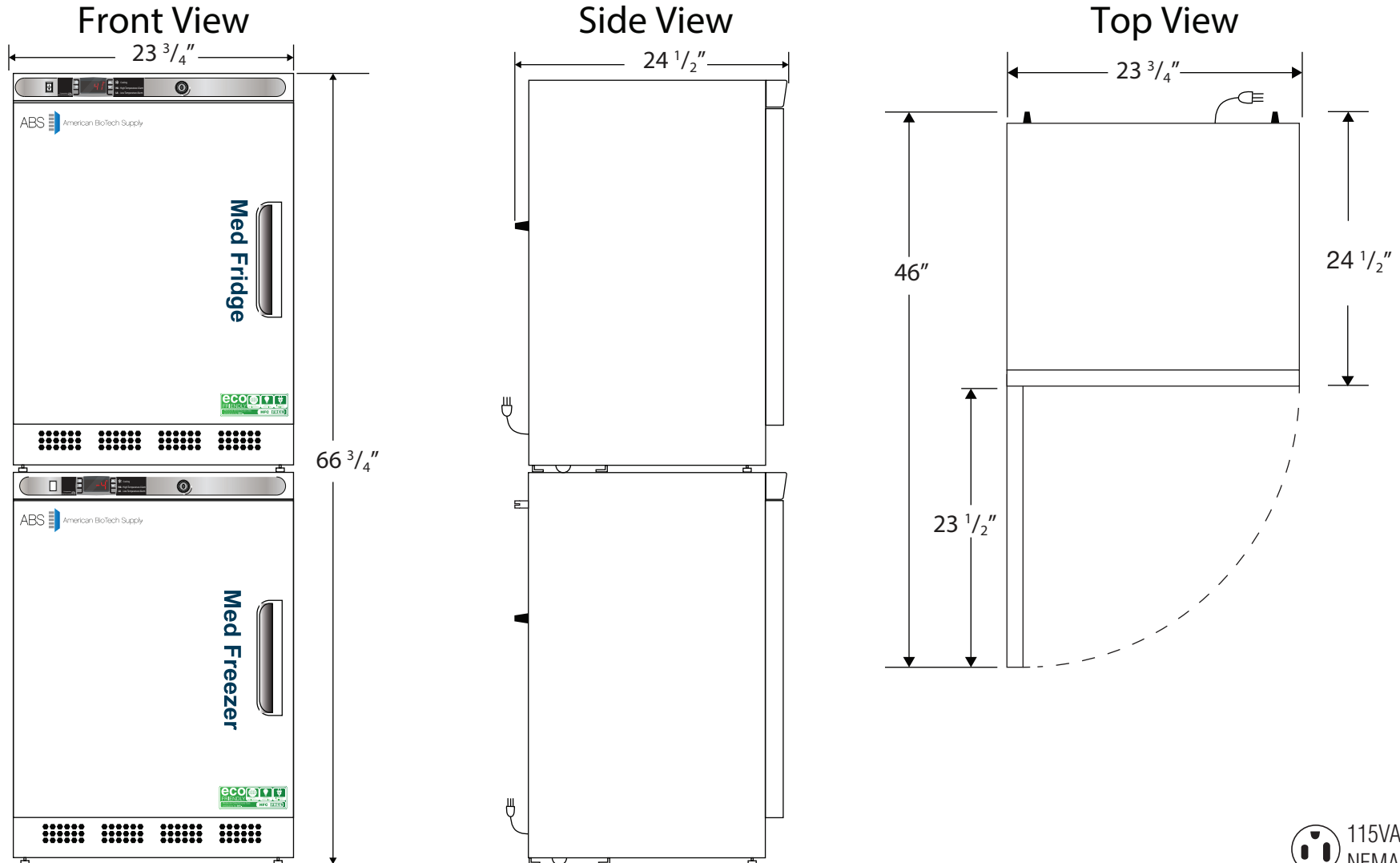

115VAC/60Hz/1PH
NEMA-5-15P

Compartment	Cu. Ft	Defrost	Door	Int Door	Shelves	W"	D"	H"	Refrigerant	H.P.	Amps	Weight
Refrigerator	4.6	Cycle	1 Solid LH	0	2 Adj./1 Fixed	23 3/4	24 1/2	66 3/4	R600a	1/8	1.74	200 lbs.
Freezer	4.2	Manual	1 Solid LH	0	2 Fixed					1/8	1.5	