

LAB11



36.25" x 28.5" x 28" (H x W x D)

-85°C capable ultra low chest freezer for laboratory and life science storage

Highlights:

Ultra low -85°C for the storage of biological samples, chemicals, select vaccines and antibiotics, industrial research, and other materials with strict temperature requirements

Extra thick 4 1/2" insulation for efficient and stable cooling

Digital thermostat with external controls allows easy and precise temperature monitoring

Product Features:

Ultra Low Temperature -85°C Chest Freezer	Designed for highly specialized cold storage applications of biological samples, DNA/RNA material, chemicals, select vaccines and antibiotics, and other substances with strict low temperature requirements
Advanced design	Interior walls feature more than 8 layers of D-shaped cooling pipes to ensure increased contact with the freezer walls in order to ensure maximum insulation and product efficiency
Manufactured by Elcold for Accucold	Designed and constructed in Denmark
Inner lids	Includes two removable inner lids for added protection from ambient air when opening the outer lid
Extra thick insulation	4 1/2" thick walls for added efficiency and stable cooling
Factory installed lock	Exterior lock on the handle for reliable security (2 keys included)
Digital thermostat	Electronic microprocessor controls for precise temperature management, with temperature readout and controls externally located for added convenience
°C/°F Readout	Temperature display can be alternated between Celsius or Fahrenheit to best suit your preference
High/low temperature alarm	Audible alarm warns if the interior temperature goes out of the set range

LAB11 Specifications:

Overview	
Height of Cabinet	36.25" (92 cm)
Width	28.5" (72 cm)
Depth	28.0" (71 cm)
Depth with Handle	30.0" (76 cm)
Capacity	4.8 cu.ft. (136 L)
Defrost Type	Manual
Door	White
Cabinet	White
US Electrical Safety	UL
Canadian Electrical Safety	ULC
Sanitation	UL-S
Amps	5.3
Voltage/Frequency	115 V AC/60 Hz
Weight	124.0 lbs. (56 kg)
Shipping Weight	140.0 lbs. (64 kg)
Parts & Labor Warranty	1 Year
Compressor Warranty	5 Years
UPC	761101085968
Freezer	
Door Swing	Lift-Up
Interior Height	26.25" (67 cm)
Interior Width	20.25" (51 cm)
Interior Depth	17.5" (44 cm)
Thermostat Type	Digital
High Side PSI	400.0
Low Side PSI	174.0
Wheels	4
Compressor Step Height	9.75" (25 cm)
Compressor Step Width	7.75" (20 cm)
Compressor Step Depth	17.5" (44 cm)
Temperature Range	-50 to -85°C
Sound Level	49 dB

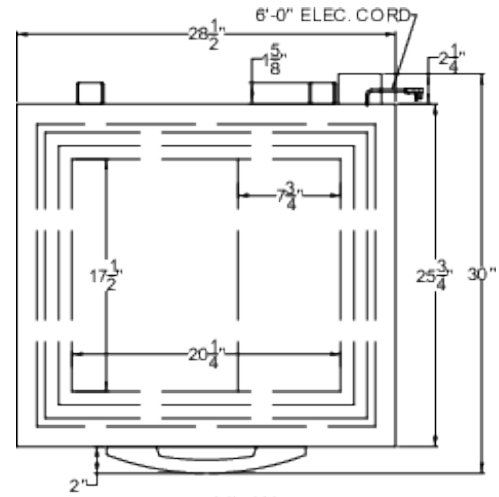

TOP VIEW

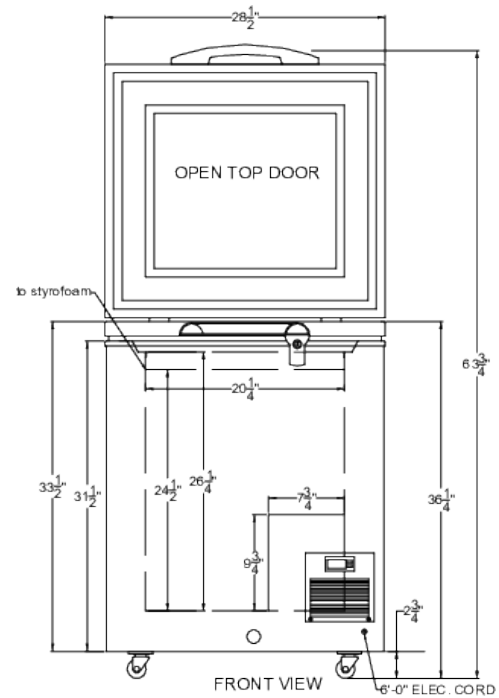

FRONT VIEW