

CUTSHEET

Front View

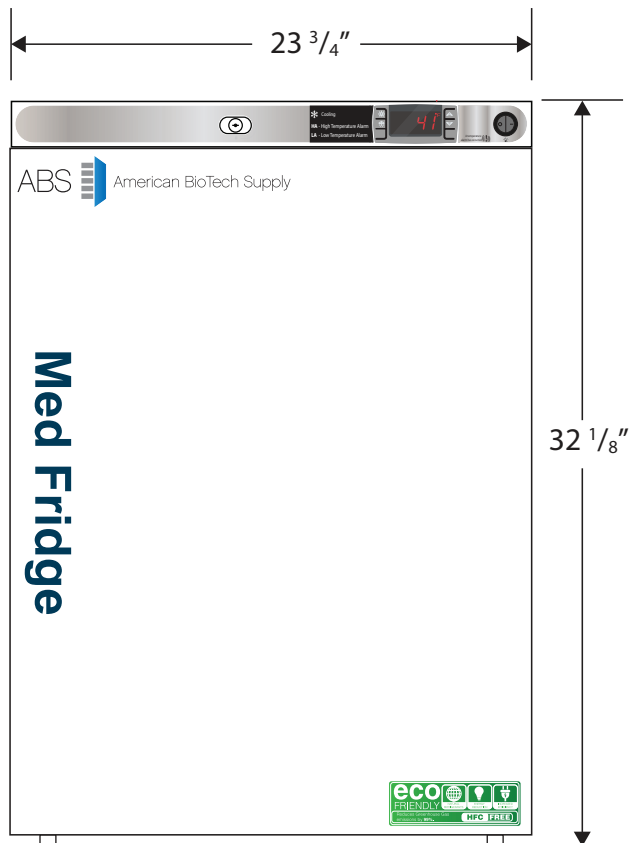

Side View

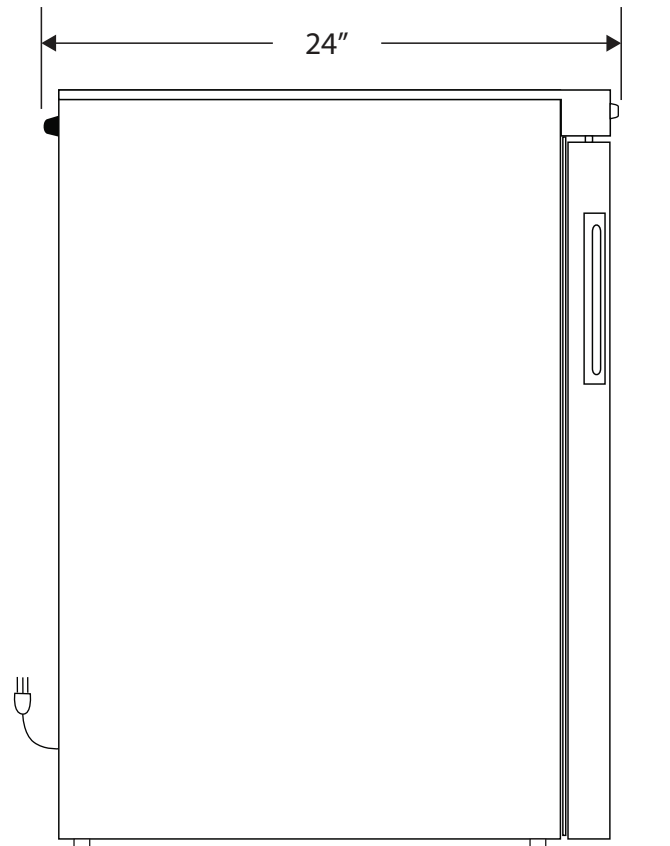

Top View

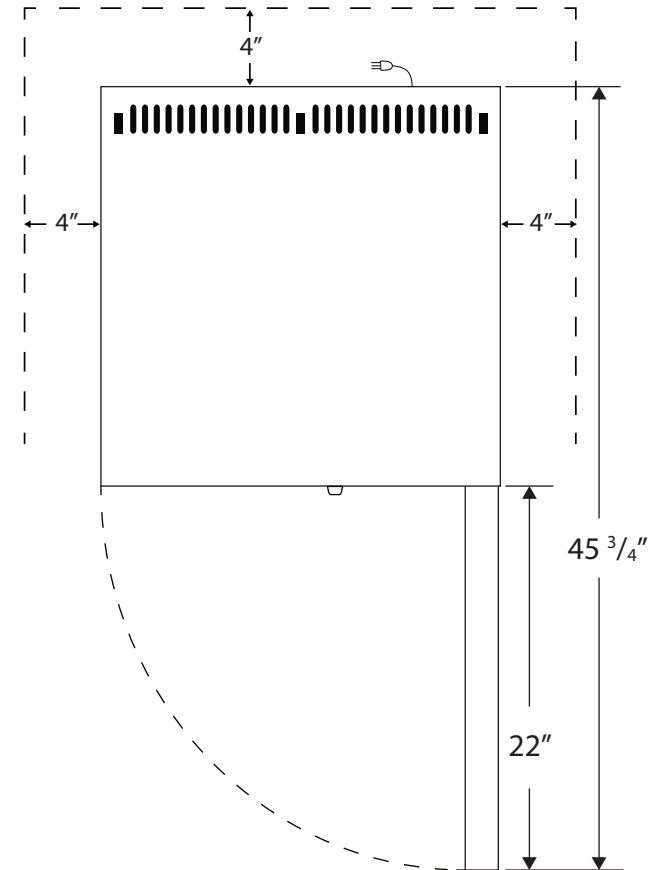

NOTE: Ventilation Requirements – Minimum 4" clearance on sides and back

115VAC/60Hz/1PH
NEMA-5-15P

Cu. Ft	Defrost	Door	Int Door	Shelves	W"	D"	H"	Refrigerant	H.P.	Amps	Weight
5.2	Cycle	1 Solid	0	3Adj +Footed Bottom	23 3/4	24	32 1/8	R600a	1/6	1.3	93 lbs.